

# **ILLUSTRATED PARTS LIST**

**MODEL NO. 96041028801**

**CUSTOMER CATALOG NO. M125-97T**

**PRODUCT NO. 960 41 02-88**

**TRACTOR - - MODEL NO. M125-97T (96041028801), PRODUCT NO. 960 41 02-88  
DECALS 27**

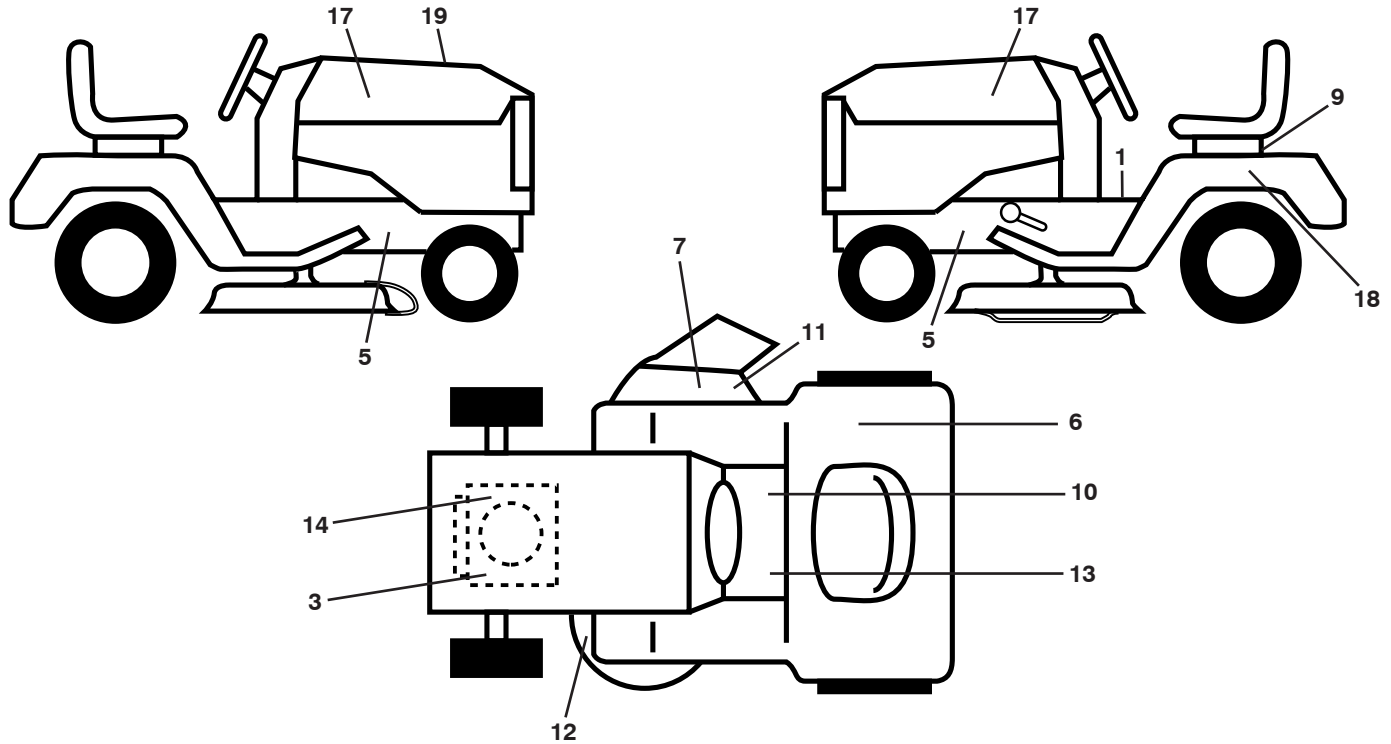

| KEY NO. | PART NO.     | DESCRIPTION                 |
|---------|--------------|-----------------------------|
| 1       | 581 57 81-01 | Decal, Operators            |
| 3       | 581 57 97-01 | Decal, Engine Warning       |
| 5       | 581 57 96-01 | Decal, Chassis Hot Muffler  |
| 6       | 581 72 41-01 | Decal, Certification        |
| 7       | 581 57 91-01 | Decal, Cutfinger CE         |
| 9       | 532 14 50-05 | Decal, Battery Dnge/Poi     |
| 10      | 581 57 80-01 | Decal, Saddle Brake Parking |
| 11      | 581 57 92-01 | Decal, Warning              |
| 12      | 581 58 00-03 | Decal, Deck Sch.            |
| 13      | 581 72 40-01 | Decal, Brake/Clutch Symbol  |
| 14      | 532 43 74-10 | Decal, BS HP                |

| KEY NO. | PART NO.     | DESCRIPTION                |
|---------|--------------|----------------------------|
| 17      | 581 09 12-01 | Decal, Hood                |
| 18      | 581 96 27-01 | Decal, Fender              |
| 19      | 584 22 02-01 | Decal, Replacement         |
| --      | 581 72 46-01 | Decal, Drawbar             |
| --      | 532 40 95-07 | Pad, Foot Pedal            |
| --      | 532 40 95-05 | Pad, Footrest, LH          |
| --      | 584 23 47-40 | Manual Operator's (Euro)   |
| --      | 581 23 47-50 | Manual Operator's (Scan)   |
| --      | 584 23 47-20 | Manual Operator's (E-Bloc) |
| --      | 584 23 47-30 | Manual Operator's (Baltic) |

**WHEELS AND TIRES**

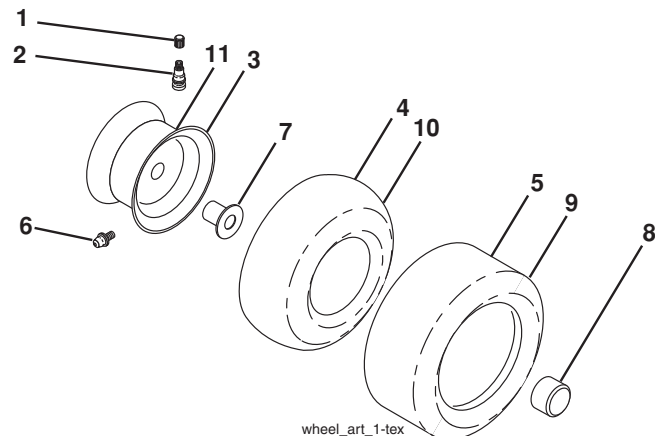

| KEY NO. | PART NO.     | DESCRIPTION                       |
|---------|--------------|-----------------------------------|
| 1       | 532 05 91-92 | Cap Valve Tire                    |
| 2       | 532 06 51-39 | Stem Valve                        |
| 3       | 532 12 51-21 | Rim Asm 6" Front                  |
| 4       | 532 05 99-04 | Tube Front (Service Item Only)    |
| 5       | 532 10 62-22 | Tire F T 15 x 6 0 - 6             |
| 6       | 532 12 49-57 | Fitting Grease (Front Wheel Only) |
| 7       | 532 12 49-59 | Bearing Flange (Front Wheel Only) |
| 8       | 532 19 32-68 | Cap Axle 1 50 x 1 00              |
| 9       | 532 12 46-35 | Tire R 18 x 9.5-8                 |
| 10      | 532 12 49-26 | Tube Rear (Service Item Only)     |
| 11      | 532 12 51-22 | Rim Asm 8" Rear                   |
| --      | 532 14 43-34 | Sealant, Tire (10 oz. Tube)       |

**NOTE:** All component dimensions given in U.S. inches  
1 inch = 25.4 mm

# TRACTOR - - MODEL NO. M125-97T (96041028801), PRODUCT NO. 960 41 02-88

## SCHEMATIC 38

SCH11

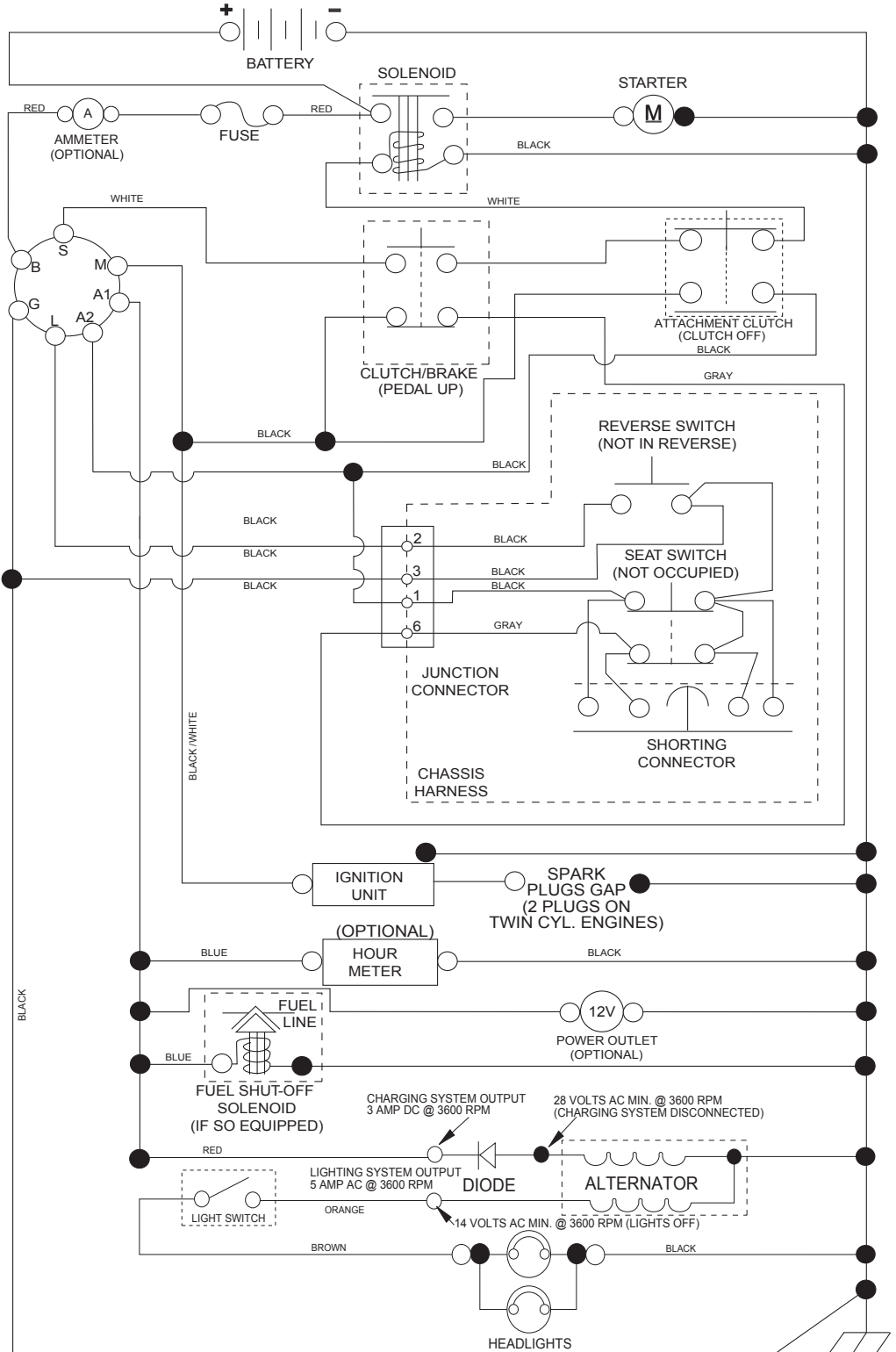

**NOTE**  
YOUR TRACTOR IS EQUIPPED WITH A SPECIAL ALTERNATOR SYSTEM. THE LIGHTS ARE NOT CONNECTED TO THE BATTERY, BUT HAVE THEIR OWN ELECTRICAL SOURCE. BECAUSE OF THIS, THE BRIGHTNESS OF THE LIGHTS WILL CHANGE WITH ENGINE SPEED. AT IDLE THE LIGHTS WILL DIM. AS THE ENGINE IS SPEEDED UP, THE LIGHTS WILL BECOME THEIR BRIGHTEST.

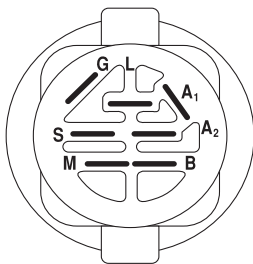

IGNITION SWITCH

| POSITION     | CIRCUIT    | "MAKE" |
|--------------|------------|--------|
| OFF          | M+G+A1     |        |
| RUN/OVERRIDE | B+A1       |        |
| RUN          | B+A1       | L+A2   |
| START        | B + S + A1 |        |

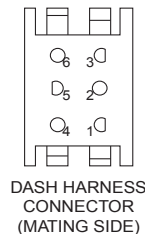
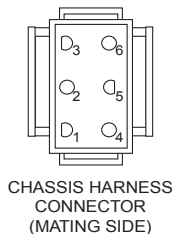

WIRING INSULATED CLIPS  
NOTE: IF WIRING INSULATED CLIPS WERE REMOVED FOR SERVICING OF UNIT, THEY SHOULD BE RE-INSTALLED TO PROPERLY SECURE YOUR WIRING.

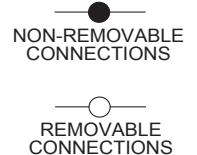

**TRACTOR - - MODEL NO. M125-97T (96041028801), PRODUCT NO. 960 41 02-88**  
**ELECTRICAL 32**

TR02K

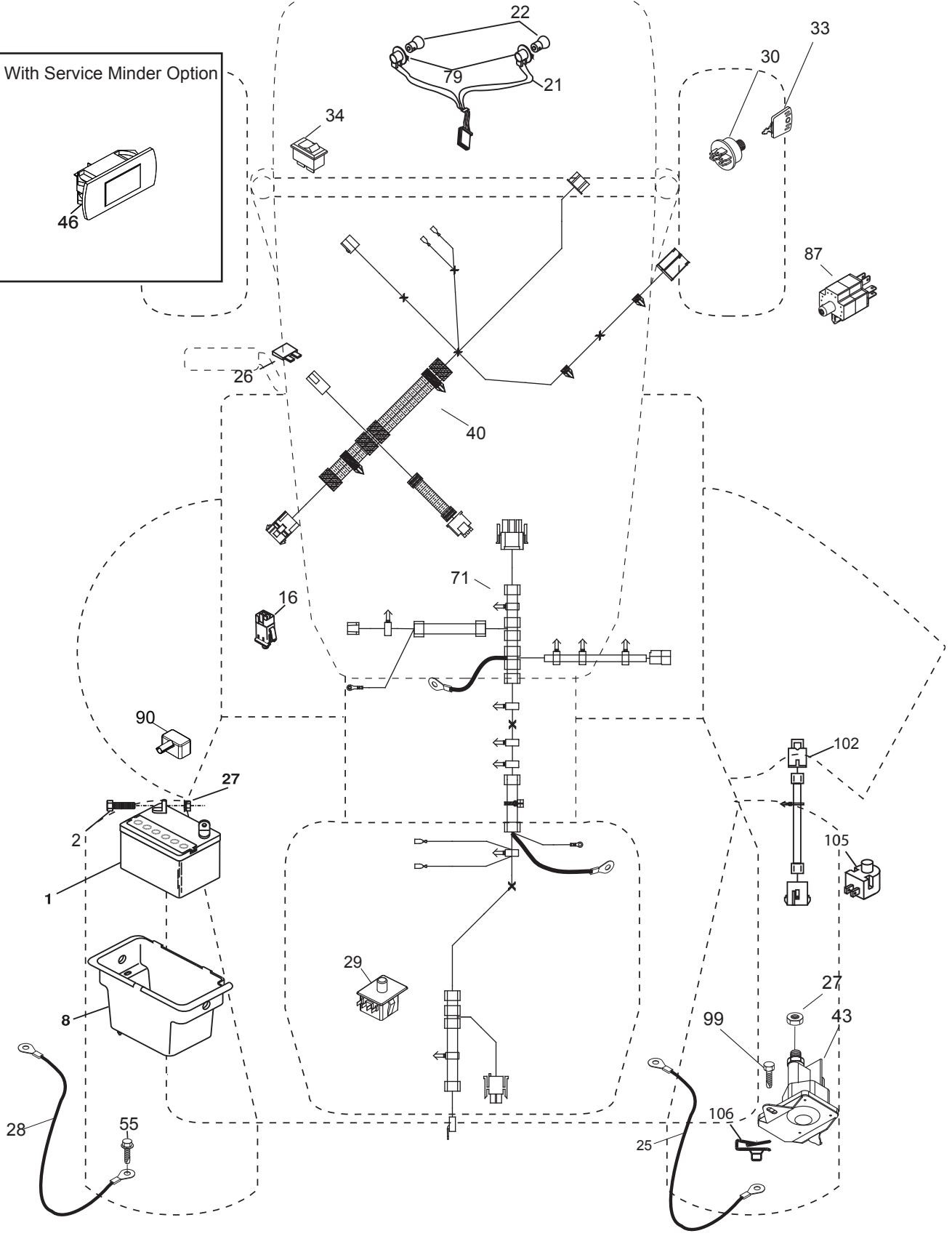
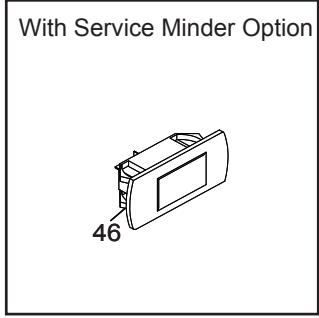

**TRACTOR - - MODEL NO. M125-97T (96041028801), PRODUCT NO. 960 41 02-88  
ELECTRICAL 32**

| <b>KEY NO.</b> | <b>PART NO.</b> | <b>DESCRIPTION</b>              |
|----------------|-----------------|---------------------------------|
| 1              | 532 16 34-65    | Battery                         |
| 2              | 874 76 04-12    | Bolt Hex Head 1/4-20 x 3/4      |
| 8              | 532 19 32-28    | Box Battery                     |
| 16             | 532 17 61-38    | Switch Interlock Push-In        |
| 21             | 532 40 02-52    | Harness Socket Light w/4152J    |
| 22             | 532 00 41-52    | Bulb Light                      |
| 25             | 581 49 80-01    | Cable Starter                   |
| 26             | 532 17 51-58    | Fuse                            |
| 27             | 873 51 04-00    | Nut Keps Hex 1/4-20 unc         |
| 28             | 532 42 16-86    | Cable,Ground                    |
| 29             | 532 40 15-45    | Switch, Seat                    |
| 30             | 532 19 33-50    | Switch, Ign                     |
| 33             | 532 41 19-35    | Key/Chain                       |
| 34             | 532 11 07-12    | Switch Light/Reset              |
| 40             | 581 02 31-01    | Harness Ign. Dash               |
| 43             | 532 19 25-07    | Solenoid                        |
| 55             | 817 06 05-12    | Screw Thdrol 5/16-18 x 3/4 TYTT |
| 71             | 581 02 30-01    | Harness Ign.                    |
| 79             | 532 17 52-42    | Socket Asm                      |
| 87             | 532 19 78-02    | Switch Interlock Clutch Cbl     |
| 90             | 532 43 53-95    | Cover Terminal                  |
| 99             | 817 67 04-12    | Screw                           |
| 102            | 532 40 44-54    | Harness Pigtail                 |
| 105            | 532 40 75-68    | Switch Reverse                  |
| 106            | 532 17 48-14    | Pal Nut                         |

**NOTE:** All component dimensions given in U.S. inches  
1 inch = 25.4 mm

TRACTOR - - MODEL NO. M125-97T (96041028801), PRODUCT NO. 960 41 02-88  
CHASSIS AND ENCLOSURES **39**

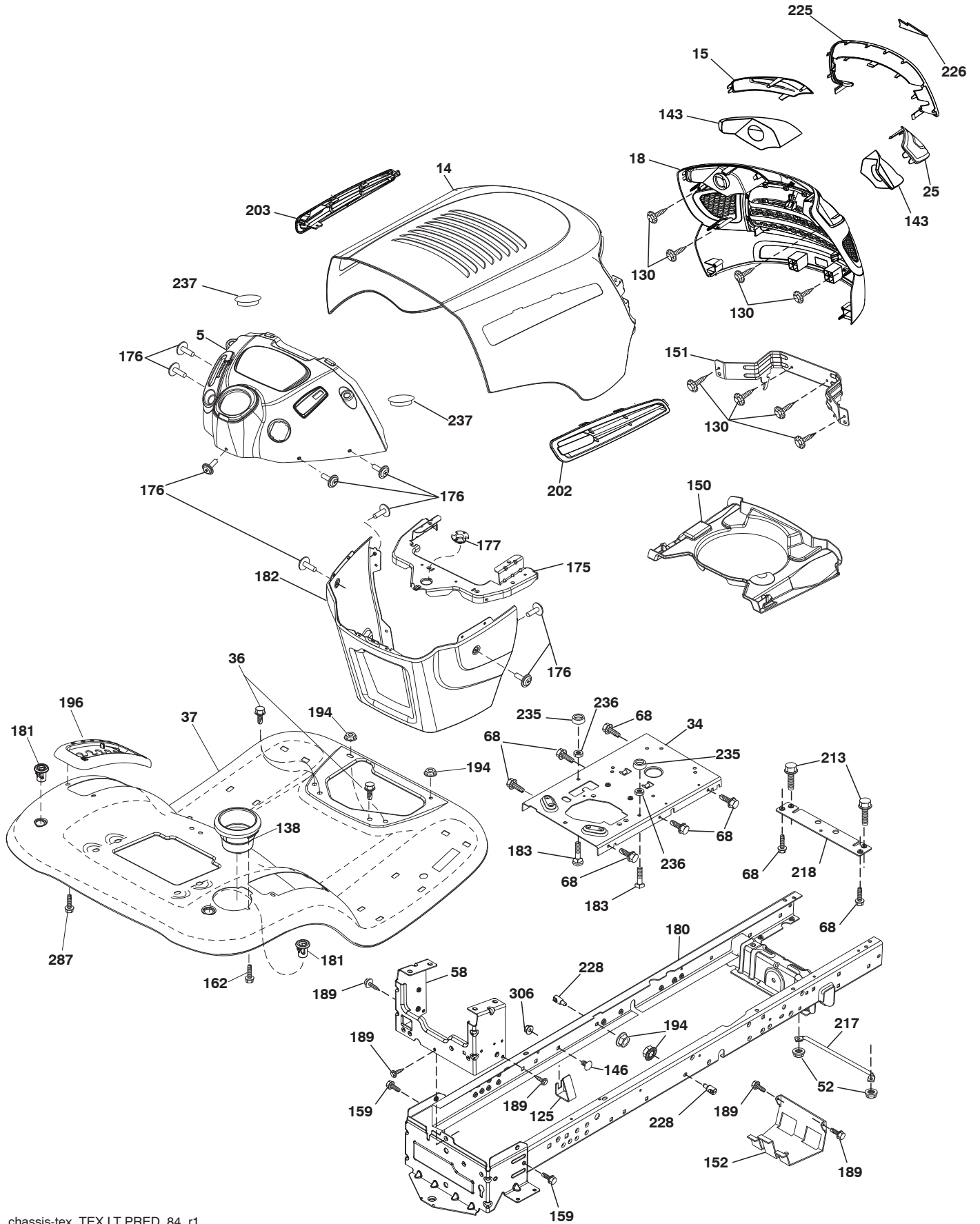

**TRACTOR - - MODEL NO. M125-97T (96041028801), PRODUCT NO. 960 41 02-88  
CHASSIS AND ENCLOSURES 39**

| <b>KEY NO.</b> | <b>PART NO.</b> | <b>DESCRIPTION</b>                |
|----------------|-----------------|-----------------------------------|
| 5              | 532 40 95-97    | Dash                              |
| 14             | 581 56 47-01    | Hood                              |
| 15             | 581 05 58-01    | Lens LH                           |
| 18             | 581 05 57-01    | Grille                            |
| 25             | 581 05 59-01    | Lens RH                           |
| 34             | 580 91 08-01    | Plate Engine                      |
| 36             | 817 06 05-12    | Screw 5/16-18 x 3/4               |
| 37             | 532 42 07-96    | Fender                            |
| 52             | 873 68 05-00    | Nut Crown Lock 5/16               |
| 58             | 532 41 22-80    | Drawbar, Upper                    |
| 68             | 817 49 05-08    | Screw THDROL 5/16-18 x 1/2        |
| 125            | 581 68 48-01    | Clip Fuel Line                    |
| 130            | 532 41 63-58    | Screw 10 x .750 BOS Thread        |
| 138            | 532 40 97-30    | Cupholder                         |
| 143            | 581 05 60-01    | Insert Reflection                 |
| 146            | 581 85 79-01    | Bolt                              |
| 150            | 532 40 02-67    | Air Duct                          |
| 151            | 532 18 75-68    | Bracket Pivot                     |
| 152            | 532 19 95-35    | Shield Browning                   |
| 159            | 817 00 06-12    | Screw Hexwsh Thdr 3/8-16 x 3/4 BL |
| 162            | 532 14 24-32    | Screw 1/4 x 1/2                   |
| 175            | 532 19 94-72    | Crossmember                       |
| 176            | 532 40 07-76    | Screw 10-24 x 5/8                 |
| 177            | 532 19 52-28    | Bushing Steering                  |
| 180            | 532 41 50-63    | Chassis                           |
| 181            | 532 40 47-96    | Bushing MNT Fender                |
| 182            | 532 40 71-76    | Dash Lower                        |
| 183            | 874 52 05-20    | Bolt 5/16-18 x 1-1/4              |
| 189            | 817 00 05-12    | Screw 5/16-18 x 3/4               |
| 194            | 873 90 05-00    | Nut Lock Hex Flange 5/16-18       |
| 196            | 532 41 45-81    | Console Deck Lift Asm.            |
| 202            | 581 56 49-01    | Vent Side Hood RH                 |
| 203            | 581 56 48-01    | Vent Side Hood LH                 |
| 213            | 874 76 05-12    | Bolt 5/16-18 x 3/4                |
| 217            | 532 40 91-67    | Rod Pivot Hood                    |
| 218            | 532 19 63-95    | X-Piece Hood Stop                 |
| 225            | 581 05 62-01    | Trim Ring                         |
| 226            | 578 89 71-01    | Emblem                            |
| 228            | 532 19 51-61    | Stud Fastener                     |
| 235            | 532 40 61-29    | Spacer Fender                     |
| 236            | 873 93 05-00    | Nut Lock 5/16-18 unc              |
| 237            | 532 40 37-04    | Plug Mount Cargo                  |
| 287            | 817 60 04-06    | Screw Hex Washhead 1/4-20 x 3/8   |
| 306            | 873 90 06-00    | Nut Lock                          |

**NOTE:** All component dimensions given in U.S. inches  
1 inch = 25.4 mm

TRACTOR - - MODEL NO. M125-97T (96041028801), PRODUCT NO. 960 41 02-88  
DRIVE **40**

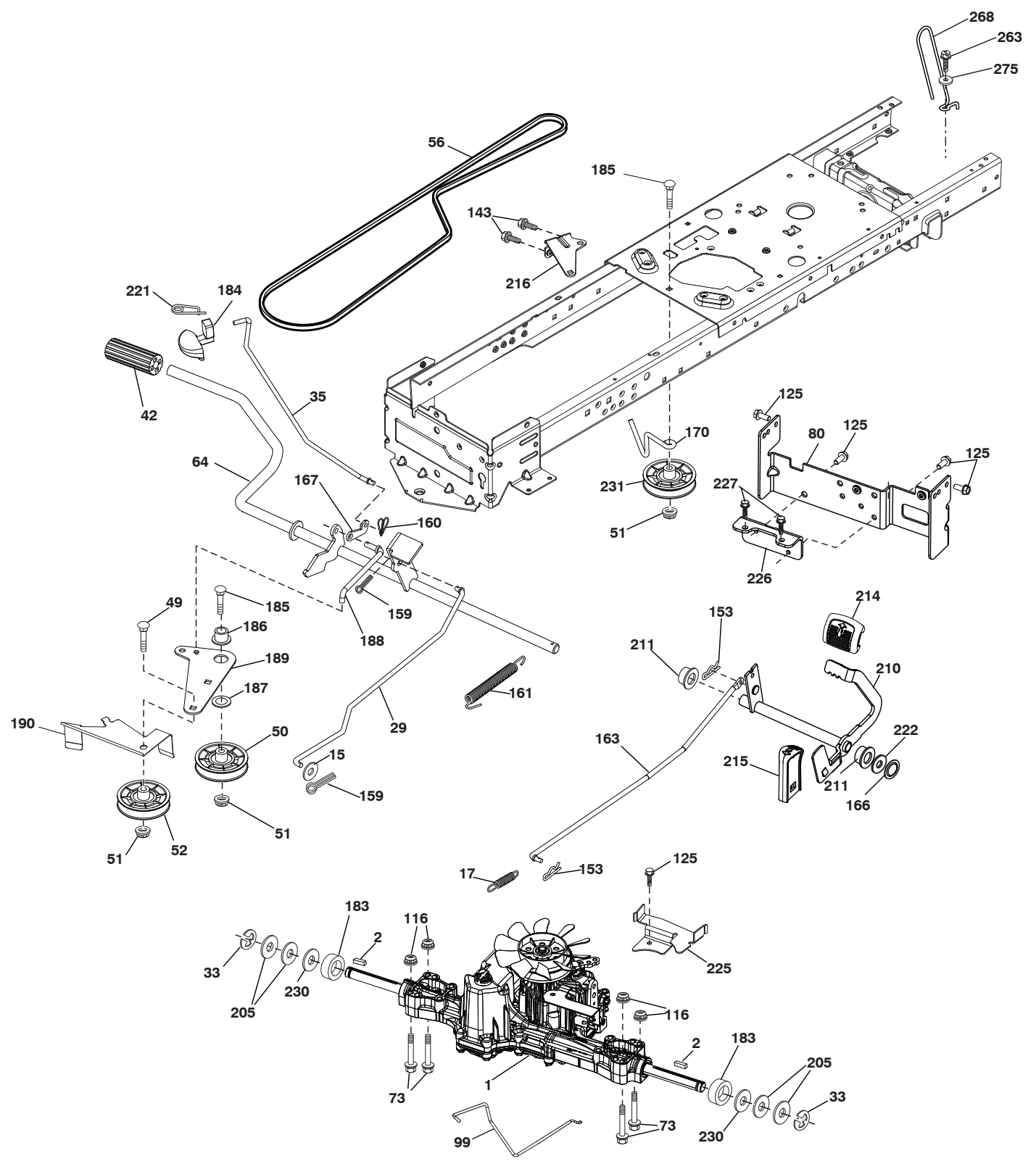



**TRACTOR - - MODEL NO. M125-97T (96041028801), PRODUCT NO. 960 41 02-88  
DRIVE 40**

| KEY NO. | PART NO.     | DESCRIPTION  | KEY NO. | PART NO.     | DESCRIPTION                      |
|---------|--------------|--|---------|--------------|----------------------------------|
| 1       | -----        | Transaxle, Tufftorq K46BT (426120)<br>(Order parts from transaxle manufacturer.) | 184     | 532 44 14-07 | Handle Parking Brake             |
| 2       | 532 12 35-83 | Key  | 185     | 872 11 06-22 | Bolt                             |
| 15      | 819 13 13-16 | Washer 13/32 x 13/16 x 16 Ga.  | 186     | 532 19 43-21 | Spacer Retainer                  |
| 17      | 532 41 36-78 | Spring, Brake  | 187     | 819 13 32-10 | Washer                           |
| 29      | 532 40 38-06 | Rod, Brake   | 188     | 532 19 43-23 | Link Clutch Ground Drive         |
| 33      | 812 00 00-01 | Ring E   | 189     | 532 19 43-17 | Bellcrank Ground Drive           |
| 35      | 532 40 10-31 | Rod, Brake, Park   | 190     | 532 19 43-18 | Keeper Bellcrank Ground Drive    |
| 42      | 532 12 48-72 | Cover, Foot Pedal  | 205     | 532 12 17-48 | Washer 25/32 x 1-5/8 x 16 Ga.    |
| 49      | 872 11 06-14 | Bolt   | 210     | 532 40 09-80 | Rockr Asm. Pdeal Control         |
| 50      | 532 19 43-27 | Pulley Idler Flat  | 211     | 532 12 01-83 | Bearing Nylon                    |
| 51      | 873 90 06-00 | Lock Nut 3/8-16  | 214     | 532 42 12-63 | Pad Pedal Forward                |
| 52      | 532 19 43-26 | Idler V-Groove   | 215     | 532 40 17-23 | Pad Pedal Reverse                |
| 56      | 532 13 09-69 | V-Belt, Drive  | 216     | 532 19 61-31 | Bracket Pulley Idler             |
| 64      | 532 19 78-65 | Shaft Asm. Pedal Brake Control   | 221     | 532 40 31-87 | Retainer Spring Clip Handle      |
| 73      | 874 49 05-40 | Bolt Hex 5/16-18 x 2.1/2 G5  | 222     | 879 21 20-10 | Washer 21/32 x 1-1/4 10 Ga.      |
| 80      | 532 44 06-19 | Strap Torque   | 225     | 532 40 33-19 | Keeper Belt Transaxle            |
| 99      | 532 41 57-42 | Rod Spring Bypass  | 226     | 532 40 15-64 | Bracket Mount Torque             |
| 116     | 873 90 05-00 | Nut Lock Hex Flange 5/16-18  | 227     | 817 49 05-12 | Screw Thdrol 5/16-18 x 3/4       |
| 125     | 817 00 05-12 | Screw 5/16-18 x 3/4  | 230     | 532 18 89-67 | Washer Harden .793 x 1.637 x 060 |
| 143     | 817 49 05-08 | Screw 5/16-18 x 1/2  | 231     | 532 40 72-87 | Idler V-Groove                   |
| 153     | 532 12 47-88 | Retainer Spring  | 263     | 817 00 06-12 | Screw                            |
| 159     | 876 02 04-12 | Pin Cotter 1/8 x 3/4   | 268     | 532 18 24-02 | Guard Muffler                    |
| 160     | 532 16 94-84 | Retainer Clip  | 275     | 819 13 16-14 | Washer 13/32 x 1 x 14            |
| 161     | 532 10 57-09 | Spring, Return, Clutch   |         |              |                                  |
| 163     | 532 44 82-75 | Rod Pedal Control  |         |              |                                  |
| 166     | 532 42 91-64 | Nut Push .625  |         |              |                                  |
| 167     | 532 40 52-57 | Latch Brake Parking  |         |              |                                  |
| 170     | 532 41 34-30 | Keeper Belt Centerspan   |         |              |                                  |
| 183     | 532 13 70-57 | Spacer Axle  |         |              |                                  |

**NOTE:** All component dimensions given in U.S. inches  
1 inch = 25.4 mm

TRACTOR - - MODEL NO. M125-97T (96041028801), PRODUCT NO. 960 41 02-88  
ENGINE **24**

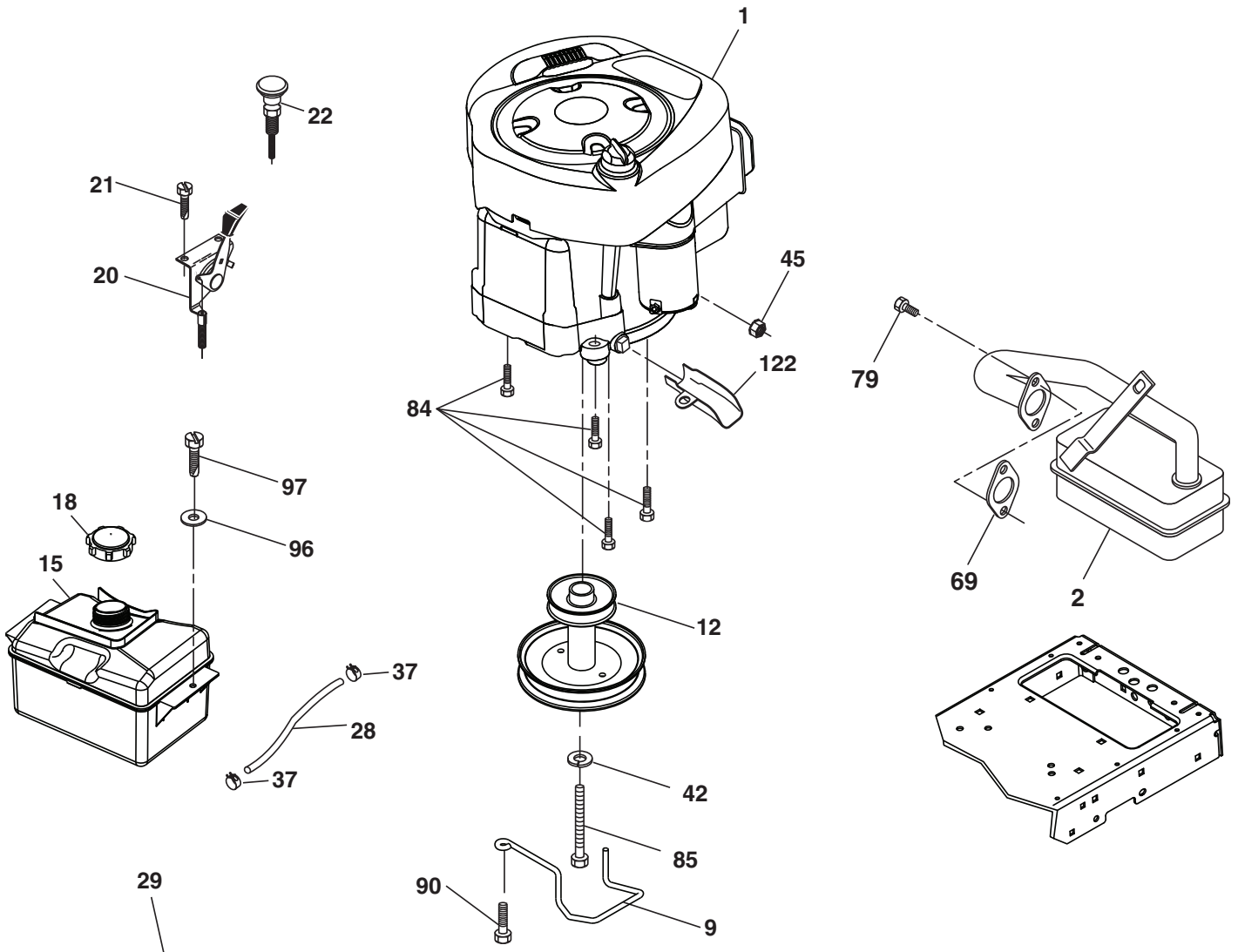

**OPTIONAL EQUIPMENT**  
**Spark Arrester**

engine-tex\_BS\_35

**TRACTOR - - MODEL NO. M125-97T (96041028801), PRODUCT NO. 960 41 02-88  
ENGINE 24**

| KEY NO. | PART NO.     | DESCRIPTION  |
|---------|--------------|--|
| 1       | ---          | Engine B & S, Model No. 219807-3402-B1 (438614)(Order parts from engine manufacturer.) |
| 2       | 532 17 97-58 | Muffler  |
| 9       | 532 19 43-20 | Keeper Belt Engine   |
| 12      | 532 40 54-71 | Pulley Engine  |
| 15      | 581 28 99-01 | Tank Fuel 1.5  |
| 18      | 532 43 02-20 | Cap Asm  |
| 20      | 532 18 38-97 | Control Throttle   |
| 21      | 532 41 63-58 | Screw #10 x .750 BOS Thread  |
| 22      | 532 19 49-81 | Control Choke  |
| 28      | 532 13 70-40 | Fuel Line  |
| 29      | 532 13 71-80 | Spark Arrester Kit   |
| 37      | 532 12 34-87 | Clamp Hose   |
| 42      | 810 04 07-00 | Washer   |
| 45      | 873 51 04-00 | Nut Keps Hex 1/4-20 unc  |
| 69      | 532 16 52-91 | Gasket   |
| 79      | 532 19 23-34 | Screw Socket 5/16-18 x .75   |
| 84      | 817 06 06-20 | Screw 3/8-16 x 1-1/4   |
| 85      | 532 17 39-37 | Bolt Hex 7/16-20 x 4 Gr. 5   |
| 90      | 817 00 06-16 | Screw 3/8-16 x 1   |
| 96      | 819 09 14-16 | Washer 9/32 x 7/8 x 16 Ga.   |
| 97      | 817 67 04-12 | Screw Hexwsh Thdrol 1/4-20 x 3/4   |
| 122     | 532 42 19-22 | Extension Drain Oil  |

**NOTE:** All component dimensions given in U.S. inches  
1 inch = 25.4 mm

**Engine Power Rating Information**

The gross power rating for individual gas engine models is labeled in accordance with SAE (Society of Automotive Engineers) code J1940 (Small Engine Power & Torque Rating Procedure), and rating performance has been obtained and corrected in accordance with SAE J1995 (Revision 2002-05). Torque values are derived at 3060 RPM; horsepower values are derived at 3600 RPM. Actual gross engine power will be lower and is affected by, among other things, ambient operating conditions and engine-to-engine variability. Given both the wide array of products on which engines are placed and the variety of environmental issues applicable to operating the equipment, the gas engine will not develop the rated gross power when used in a given piece of power equipment (actual "on-site" or net power). This difference is due to a variety of factors including, but not limited to, accessories (air cleaner, exhaust, charging, cooling, carburetor, fuel pump, etc.), application limitations, ambient operating conditions (temperature, humidity, altitude), and engine-to-engine variability. Due to manufacturing and capacity limitations, Briggs & Stratton may substitute an engine of higher rated power for this Series engine.

TRACTOR - - MODEL NO. M125-97T (96041028801), PRODUCT NO. 960 41 02-88  
STEERING ASSEMBLY **41**

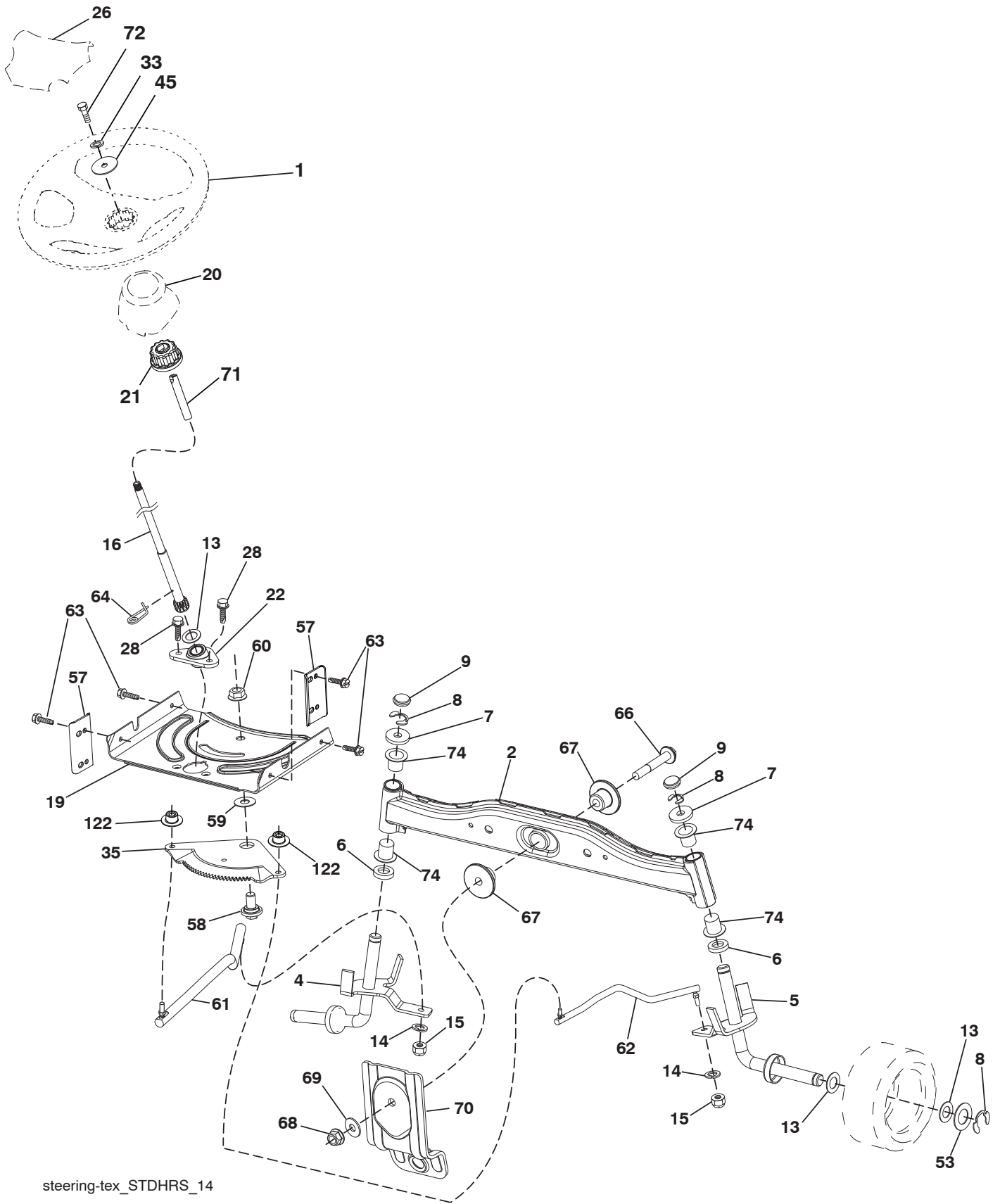

steering-tex\_STDHRS\_14

**TRACTOR - - MODEL NO. M125-97T (96041028801), PRODUCT NO. 960 41 02-88**  
**STEERING ASSEMBLY 41**

| <b>KEY NO.</b> | <b>PART NO.</b> | <b>DESCRIPTION</b>                 |
|----------------|-----------------|------------------------------------|
| 1              | 532 44 28-04    | Wheel, Steering                    |
| 2              | 532 41 81-68    | Axle Asm., Front                   |
| 4              | 532 40 30-87    | Spindle Asm., LH                   |
| 5              | 532 40 30-88    | Spindle Asm., RH                   |
| 6              | 532 12 49-31    | Bearing, Race Thrust Hardened      |
| 7              | 532 12 17-48    | Washer 25/32 x 1-5/8 x 16 Ga.      |
| 8              | 812 00 00-29    | Ring, Klip #T5304-75               |
| 9              | 532 12 12-32    | Cap, Spindle                       |
| 13             | 532 12 17-49    | Washer, 25/32 x 1-1/4 x 16 Ga.     |
| 14             | 810 04 06-00    | Washer, Lock Hvy Hlcl Spr 3/8      |
| 15             | 873 54 06-00    | Nut, Crown Lock 3/8-24 unf         |
| 16             | 532 42 93-73    | Shaft Steering                     |
| 19             | 532 19 47-29    | Plate Steering                     |
| 20             | 532 40 97-63    | Boot, Steering                     |
| 21             | 532 18 67-37    | Adapter, Wheel Steering            |
| 22             | 532 42 05-37    | Steering Support                   |
| 26             | 532 44 77-59    | Insert, Wheel Steering             |
| 28             | 817 00 06-12    | Screw 3/8-16 x 3/4                 |
| 33             | 810 04 05-00    | Washer Lock 5/16                   |
| 35             | 532 19 47-32    | Gear, Sector Plate                 |
| 45             | 819 11 38-12    | Washer 11/32 x 3/8 x 12 Ga.        |
| 53             | 532 18 89-67    | Washer Hardened .793x1.637x.060    |
| 57             | 532 40 74-65    | Bracket Upstop                     |
| 58             | 532 19 47-47    | Bolt Shoulder Sector Pivot CFM     |
| 59             | 532 19 47-48    | Washer Thrust Sector Steering      |
| 60             | 873 97 10-00    | Nut Flange Lock 5/8-11             |
| 61             | 532 19 47-40    | Draglink, LH                       |
| 62             | 532 19 47-41    | Draglink, RH                       |
| 63             | 817 00 05-12    | Screw 5/16-18 x 3/4                |
| 64             | 532 19 98-49    | Retainer Clip Spring Steering      |
| 66             | 871 02 07-48    | Bolt Hex Fghd 7/16-14 x 3 Serr     |
| 67             | 532 19 47-37    | Bushing PM Front Axle              |
| 68             | 873 90 07-00    | Nut Lock Flange 7/16-14 Gr. 5      |
| 69             | 532 19 91-62    | Washer 1.5 x .505 x .118           |
| 70             | 532 19 61-97    | Bracket Deck Susp. Front           |
| 71             | 532 19 07-52    | Shaft Extension Steering           |
| 72             | 532 42 89-82    | Bolt Fin Hex 5/16-18 x 3/4 w/Patch |
| 74             | 532 12 49-37    | Bearing                            |
| 122            | 532 44 49-62    | Cap Gear                           |

**NOTE:** All component dimensions given in U.S. inches  
1 inch = 25.4 mm

TRACTOR - - MODEL NO. M125-97T (96041028801), PRODUCT NO. 960 41 02-88  
MOWER DECK 44

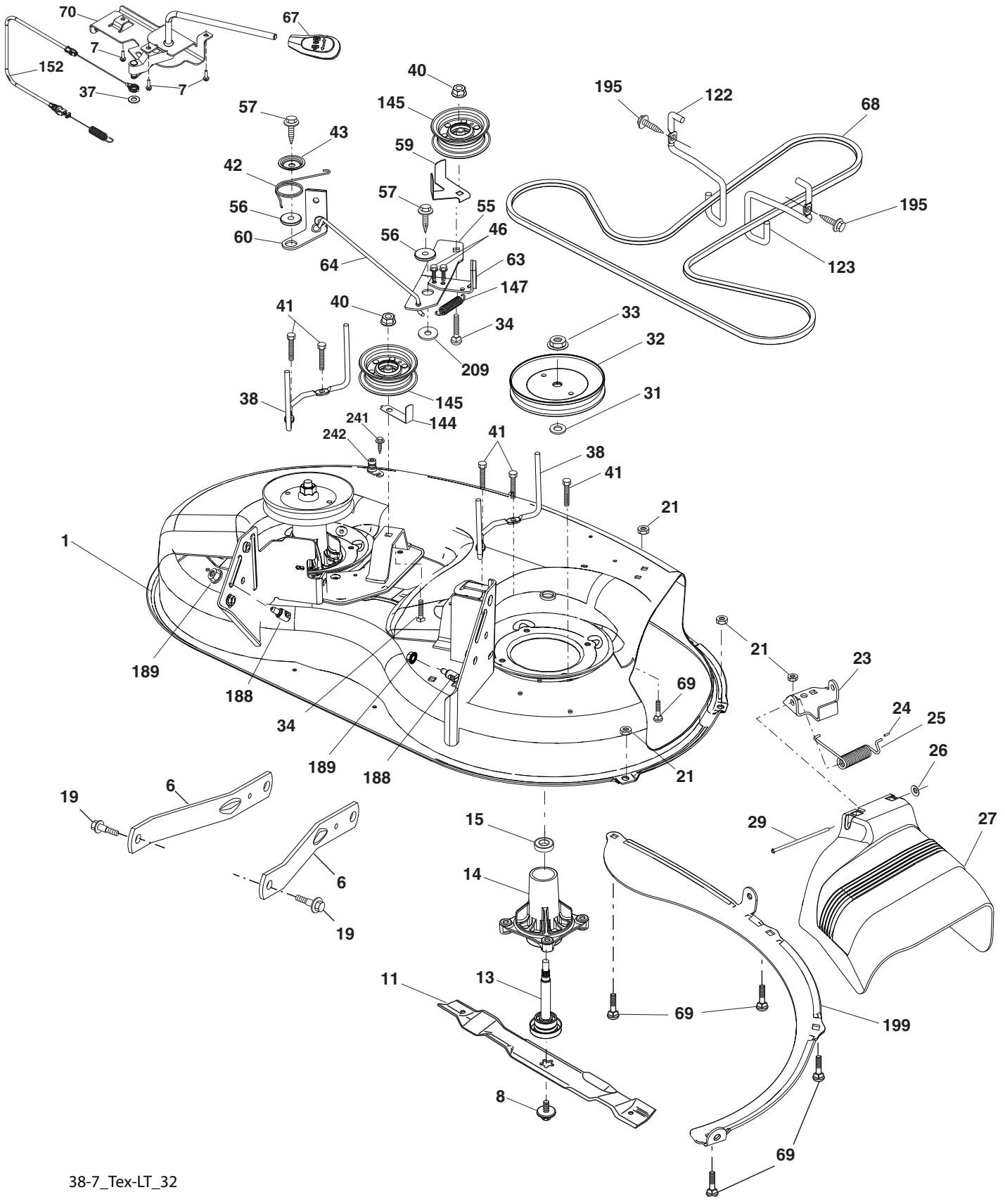

38-7\_Tex-LT\_32

**TRACTOR - - MODEL NO. M125-97T (96041028801), PRODUCT NO. 960 41 02-88  
MOWER DECK 44**

| KEY<br>NO. | PART<br>NO.  | DESCRIPTION                         | KEY<br>NO. | PART<br>NO.  | DESCRIPTION   |
|------------|--------------|-------------------------------------|------------|--------------|---|
| 1          | 532 19 42-51 | Mower Housing                       | 63         | 532 19 94-70 | Arm Brake Mower   |
| 6          | 532 19 51-86 | Arm Suspension                      | 64         | 532 19 97-90 | Link Brake  |
| 7          | 532 41 63-58 | Screw #10 x 0.750 BOS Thread        | 67         | 532 40 30-12 | Handle Clutch Cable   |
| 8          | 532 19 30-03 | Bolt/Washer Asm. 7/16-20 unf        | 68         | 532 40 83-81 | V-Belt  |
| 11         | 532 19 39-57 | Blade 38" 3Ni Premium               | 69         | 872 14 05-05 | Bolt  |
| 13         | 532 19 28-72 | Shaft Assembly, Mandrel             | 70         | 532 40 12-46 | Clutch Asm. Manual  |
| 14         | 532 18 72-81 | Housing, Mandrel                    | 122        | 532 19 72-58 | Keeper Belt Engine LH   |
| 15         | 532 11 04-85 | Bearing, Ball, Mandrel              | 123        | 532 19 72-59 | Keeper Belt Engine RH   |
| 19         | 532 19 65-39 | Bolt, Shoulder                      | 144        | 532 19 34-14 | Keeper Belt   |
| 21         | 873 68 05-00 | Nut, Crownlock 5/16-18 unc          | 145        | 532 19 31-97 | Pulley Idler  |
| 23         | 532 19 25-57 | Bracket, Deflector                  | 147        | 532 40 18-72 | Spring Return   |
| 24         | 532 10 53-04 | Cap, Sleeve                         | 152        | 532 43 51-11 | Manual Clutch Cable   |
| 25         | 532 19 70-26 | Spring, Torsion, Deflector          | 188        | 532 19 51-61 | Stud Fastener   |
| 26         | 532 11 04-52 | Nut, Push                           | 189        | 873 90 05-00 | Nut Lock Hex Flange   |
| 27         | 532 40 14-72 | Shield, Deflector                   | 195        | 817 00 06-12 | Screw 3/8-16 x 3/4  |
| 29         | 532 13 14-91 | Rod, Hinge                          | 199        | 532 40 00-95 | Baffle Vortex   |
| 31         | 532 18 76-90 | Washer, Spacer                      | 209        | 819 13 32-10 | Washer 13/32 x 2 x 10   |
| 32         | 532 19 97-89 | Pulley, Mandrel                     | 241        | 532 15 29-27 | Screw TT #10-32.5 3/8   |
| 33         | 532 40 02-34 | Nut, Toplock, Flanged               | 242        | 532 41 55-98 | Port Washout  |
| 34         | 872 11 06-12 | Bolt Carr. Sh. 3/8-16 x 1-1/2 Gr. 5 | --         | 532 19 28-70 | Mandrel Assembly (Includes housing<br>(key# 14), shaft assembly (key# 13),<br>and bearing (key# 15) only - pulley/<br>nut/washer and blade bolt/washers<br>not included.) |
| 37         | 819 13 13-16 | Washer                              |            |              |   |
| 38         | 532 19 95-41 | Keeper Belt LH Mandrel              |            |              |   |
| 40         | 873 90 06-00 | Nut, Lock Flg. 3/8-16 unc           |            |              |   |
| 41         | 584 95 39-01 | Bolt Hex Wshr                       |            |              |   |
| 42         | 532 19 84-10 | Spring Torsion Brake                | --         | 532 40 04-22 | Replacement Mower, Complete   |
| 43         | 532 19 72-56 | Spring Torsion Retainer             |            |              |   |
| 46         | 532 13 77-29 | Screw 1/4 - 20 x 5/8                |            |              |   |
| 55         | 532 19 72-49 | Arm, Idler                          |            |              |   |
| 56         | 532 19 90-92 | Spacer, Retainer                    |            |              |   |
| 57         | 817 00 06-16 | Screw 3/8-16 x 1                    |            |              |   |
| 59         | 532 14 10-43 | Guard, Tuv. Idler                   |            |              |   |
| 60         | 532 19 94-71 | Arm Brake Mower                     |            |              |   |

**NOTE:** All component dimensions given in U.S. inches  
1 inch = 25.4 mm

**TRACTOR - - MODEL NO. M125-97T (96041028801), PRODUCT NO. 960 41 02-88**  
**MOWER LIFT 45**

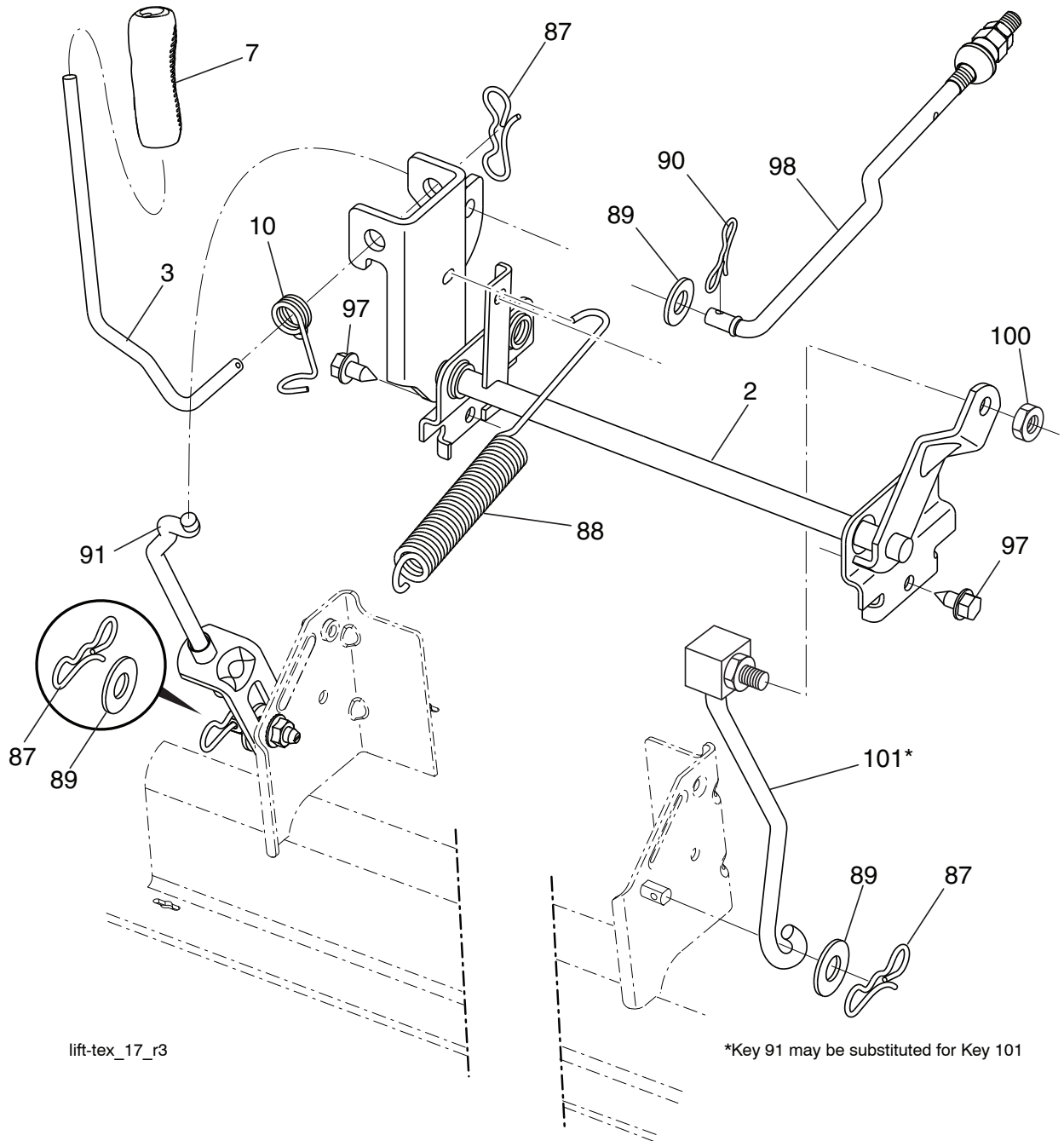

| KEY NO. | PART NO.     | DESCRIPTION                  |
|---------|--------------|------------------------------|
| 2       | 532 42 20-27 | Shaft Asm., Lift             |
| 3       | 532 19 52-31 | Lever Asm., Lift RH          |
| 7       | 580 96 23-01 | Grip, Lever                  |
| 10      | 532 19 63-14 | Spring Torsion               |
| 87      | 532 19 42-09 | Pin Cotter 7/16 Bow Tie Lock |
| 88      | 532 41-07-10 | Spring Lift Assist           |
| 89      | 819 19 19-12 | Washer Clear Zinc            |
| 90      | 532 19 42-08 | Pin Cotter 5/16 Bow Tie Lock |

| KEY NO. | PART NO.     | DESCRIPTION                 |
|---------|--------------|-----------------------------|
| 91      | 532 19 51-81 | Link Lift Susp Mower Rear   |
| 97      | 817 00 06-12 | Screw 3/8-16 x .75          |
| 98      | 532 19 52-70 | Link Lift Susp. Front Mower |
| 100     | 873 93 06-00 | Nut Centerlock 3/8-16       |
| 101     | 532 40-70-03 | Link Asm. Lift FXD          |

**NOTE:** All component dimensions given in U.S. inches  
 1 inch = 25.4 mm



**TRACTOR - - MODEL NO. M125-97T (96041028801), PRODUCT NO. 960 41 02-88  
SEAT ASSEMBLY 42**

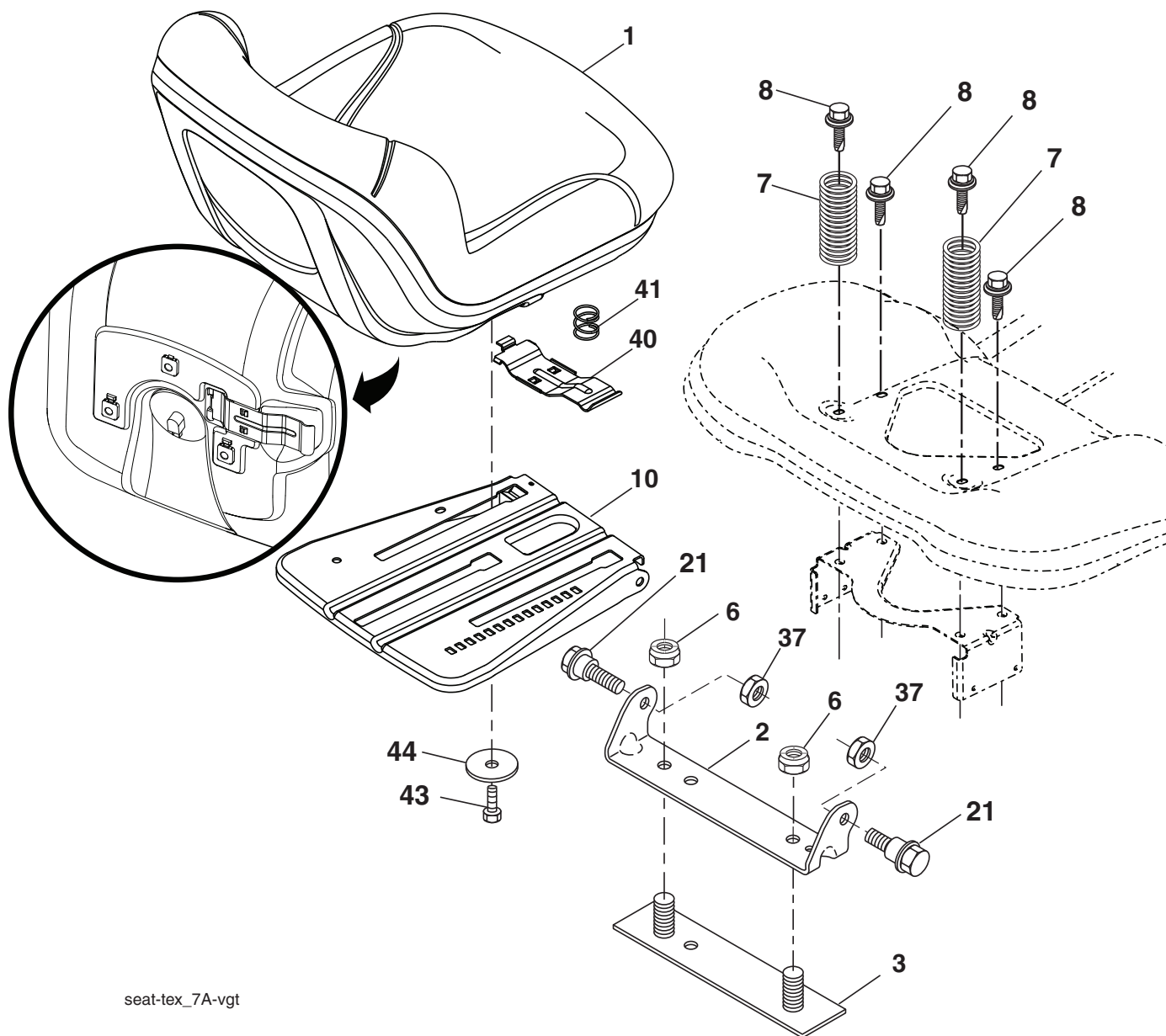

seat-tex\_7A-vgt

| KEY NO. | PART NO.     | DESCRIPTION                   |
|---------|--------------|-------------------------------|
| 1       | 581 46 20-01 | Seat                          |
| 2       | 532 18 01-66 | Bracket Pivot Fender          |
| 3       | 532 14 06-75 | Strap, Asm Fender             |
| 6       | 873 80 06-00 | Nut, Lock w/Ins. 3/8-16 unc   |
| 7       | 532 12 41-81 | Spring, Seat Cprsn            |
| 8       | 532 17 18-77 | Bolt 5/16-18 unc x 3/4 w/Sems |
| 10      | 532 19 69-77 | Pan, Seat                     |
| 21      | 532 17 18-52 | Bolt, Shoulder 5/16-18        |

| KEY NO. | PART NO.     | DESCRIPTION                   |
|---------|--------------|-------------------------------|
| 37      | 873 80 05-00 | Nut, Lock 5/16-18 unc         |
| 40      | 532 19 76-61 | Handle Slide                  |
| 41      | 532 19 82-00 | Spring Latch                  |
| 43      | 874 76 06-12 | Bolt Fin Hex 3/8-16 unc x 3/4 |
| 44      | 819 13 38-12 | Washer 13/32 x 2-3/8 x 12 Ga. |

**NOTE:** All component dimensions given in U.S. inches  
1 inch = 25.4 mm

